

SPARE PARTS

- COVERING GLASS OF THE SCALE
ORDER NO.: 0450-08
- MEASURING CONTACT
ORDER NO.: 0251-02
- HANDLE
ORDER NO.: 0450-13

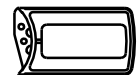

SCALE 1:2

SUBJECT TO TECHNICAL ALTERATIONS

TYPE: Intertest PRICECLASS: 26
RANGE OF APPLICATION: 5.9" – 7.9"
SCALE INTERVAL: .001"

MEASURING FORCE: 1.2–2.0N
WEIGHT: 520g

ACCEPTABLE DEVIATIONS (VDI/VDE/DGQ 2618 Bl. 12.1/13.1)

MAX. PERMISSIBLE ERRORS $G = .003''$
REPEATABILITY $r = .001''$

REFERENCE TEMPERATURE: 20°C
OPERATION TEMPERATURE: 10°C – 30°C
STORAGE TEMPERATURE: -10°C – 50°C

SHAPES OF CONTACTS

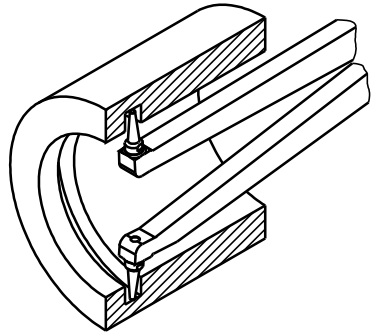

HM-BALLS ϕ .079"

		MEASURING RANGE M [inch]									
		5.9	6.1	6.22	6.38	6.54	6.69	6.89	7.09	7.48	7.9
GROOVE DEPTH A [inch]	0	0/6.6	0/7.8	0/6.9	0/7.0	0/7.0	0/7.0	0/7.0	0/7.0	0/7.0	0/7.0
	.08		.083/6.7	.083/6.8	.083/7.0	.083/7.0	.083/7.0	.083/7.0	.083/7.0	.083/7.0	.083/7.0
.16			.087/6.9	.087/6.9	.087/7.0	.087/7.0	.087/7.0	.087/7.0	.087/7.0	.087/7.0	.098/7.0
.24				.098/6.8	.098/6.9	.098/7.0	.098/7.0	.098/7.0	.098/7.0	.102/7.0	.114/7.0
.31					.11/6.8	.11/7.0	.11/7.0	.11/7.0	.11/7.0	.114/7.0	.13/7.0
.39						.122/6.9	.122/7.0	.122/7.0	.122/7.0	.126/7.0	.146/7.0
		B/L									

B = MINIMUM GROOV WIDTH [inch]
 L = MAXIMUM USABLE ARM LENGTH [inch]
 EXAMPLE: M= 6.38" > B= .087"
 A= .16" L= 6.9"

