



Series X Gear-drive Round-column Drills

With Manual or Mechanical Clutch

The X series range of easy to operate Industrial Drilling Machines offer a variety of capacities and feeds. Engineered for a long work life the X series drills are a great value. SX models are equipped with manual feed, AX models are equipped with a mechanical clutch automatic feed control.

Standard Features and Equipment:

- Drilling capacity in steel: up to 1.26" (32mm) maximum
- Drilling capacity in cast iron: up to 1.38" (35mm) maximum
- Tapping capacity in steel: up to .87" (22mm) maximum
- Tapping capacity in cast iron: up to 1.18" (30mm) maximum
- Automatic feed reversing system for tapping on "RS" models
- Hardened and ground high quality steel gears
- Speed plate and selecting levers on front of head
- Gear box lubrication by automatic pump
- Machine base with 2 T-slots, coolant tank and pump
- Large worktable with 3 T-slots
- Feed crank wheel for manual feed
- Depth scale and adjustable depth stop
- Automatic tool ejector
- Work Light
- Built-in low voltage electrical equipment in machine head
- Emergency STOP
- Drill guard with microswitch

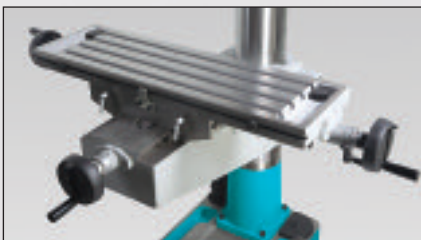

*Optional MCC-ZX
15" x 8.7" cross
slide table for
model X32*



*Optional MG
rotating table
with 3 T-slots for
model X32*



AX32

*Head mounted speed controls for
easy spindle speed setting*

Capacities, Specifications and Dimensions

Standard Models Auto feed reversing "RS" Models	SX32 SX32RS	AX32 AX32RS
Capacities:		
Maximum drilling capacity in steel	1.26" (32mm)	1.26" (32mm)
Maximum drilling capacity in cast iron	1.38" (35mm)	1.38" (35mm)
Maximum tapping capacity in steel	.87" (22mm)	.87" (22mm)
Maximum tapping capacity in cast iron	1.18" (30mm)	1.18" (30mm)
Specifications:		
Spindle taper	3MT	3MT
Quill diameter	2.56" (65mm)	2.56" (65mm)
Spindle travel (drilling depth)	5.91" (150mm)	5.91" (150mm)
Main motor power	1.5 Hp (1.1Kw)	1.5 Hp (1.1Kw)
Coolant pump motor power	.1 Hp (.07Kw)	.1 Hp (.07Kw)
Number of speeds	9	9
Number of automatic feeds	-	2
Auto feed range: in./rev. (mm/rev)	-	.0039/.0079 (0.1-0.2)
Dimensions and Weights		
Height (A)	87.4" (2220mm)	87.4" (2220mm)
Base: Length x Width (B)	26.8" x 16.5" (680 x 420mm)	26.8" x 16.5" (680 x 420mm)
Base to spindle (C)	50.39" (1280mm)	50.39" (1280mm)
Spindle center to column (D)	11.81" (300mm)	11.81" (300mm)
Spindle to Table (E)		
Minimum	5.71" (145mm)	5.71" (145mm)
Maximum	31.89" (810mm)	31.89" (810mm)
Worktable: Length x Width (F)	15.75" x 18.9" (400 x 480mm)	15.75" x 18.9" (400 x 480mm)
Base height (G)	4.72" (120mm)	4.72" (120mm)
Column diameter (H)	4.92" (125mm)	4.92" (125mm)
Net weight	694 lbs (315Kg)	728 lbs (330Kg)
Shipping weight	794 lbs (360Kg)	827 lbs (375Kg)
Shipping dimension (L x W x H)	24" x 44" x 91" (.6x1.1x2.3m)	24" x 44" x 91" (.6x1.1x2.3m)

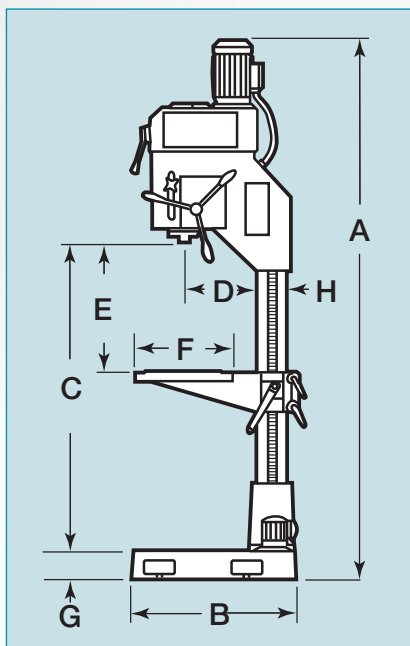

Standard motor: 1800 rpm

Spindle speeds SX32, AX32

123-180-257-295-432-617-820-1200-1714 rpm

Optional spindle motors

Motor	Speed range
1200 rpm	63-1000 rpm
3600 rpm	250-3480 rpm
900/1800 rpm	63-1000 rpm
1800-3600 rpm	123-3428 rpm

Standard Fixed Table Models

Model	Description (Dimension see page 21)
1SX32	23.6" (600mm) drill with Fixed Table
1SX32RS	23.6" (600mm) drill with Fixed Table and Tapping System
1AX32	23.6" (600mm) drill with Fixed Table
1AX32RS	23.6" (600mm) drill with Fixed Table and Tapping System

"RS" models are equipped with automatic feed reversing system for tapping.