



Series X Gear-drive Round-column Drills

*With Manual, Mechanical Clutch or
Electromagnetic Clutch Feed Control*

The X series range of easy to operate Industrial Drilling Machines offer a variety of capacities and feeds. Engineered for a long work life the X series drills are a great value. SX models are equipped with manual feed, AX models are equipped with a mechanical clutch automatic feed control and the BX models are equipped with electromagnetic automatic feed control.

Standard Features and Equipment:

- Drilling capacity in steel: up to 1.57" (40mm) maximum
- Drilling capacity in cast iron: up to 1.77" (45mm) maximum
- Tapping capacity in steel: up to 1.30" (33mm) maximum
- Tapping capacity in cast iron: up to 1.54" (39mm) maximum
- Automatic feed reversing system for tapping on "RS" models
- Hardened and ground high quality steel gears
- Speed plate and selecting levers on front of head
- Gear box lubrication by automatic pump
- Machine base with 2 T-slots, coolant tank and pump
- Large rotating worktable with 3 T-slots
- Feed crank wheel for manual feed
- Depth scale and adjustable depth stop
- Automatic tool ejector • Work Light
- Built-in low voltage electrical equipment in machine head
- Emergency STOP • Drill guard with microswitch

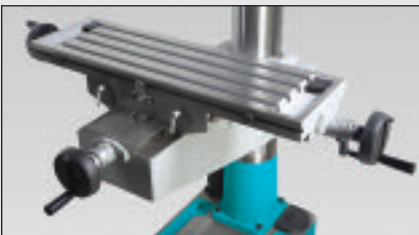

*Optional 15" x 8.7"
cross slide table
MCC-ZX X34
MCC-X40 X40*



*Optional MGM
rotating table with
3 T-slots on one side
and a vise on the
other for model X34*



BX40

Capacities, Specifications and Dimensions

Standard Models Auto feed reversing "RS" Models	SX/AX/BX34 SX/AX/BX34RS	SX/AX/BX40 SX/AX/BX40RS
Capacities:		
Maximum drilling capacity in steel	1.34" (34mm)	1.57" (40mm)
Maximum drilling capacity in cast iron	1.57" (40mm)	1.77" (45mm)
Maximum tapping capacity in steel	1.06" (27mm)	1.30" (33mm)
Maximum tapping capacity in cast iron	1.30" (33mm)	1.54" (39mm)
Specifications:		
Spindle taper	4MT	4MT
Quill diameter	2.95" (75mm)	2.95" (75mm)
Spindle travel (drilling depth)	5.9" (150mm)	7.09" (180mm)
Main motor power	2 Hp (1.5Kw)	3 Hp (2.2Kw)
Coolant pump motor power	.1 Hp (.07Kw)	.1 Hp (.07Kw)
Number speeds	9	9
Number of automatic feeds	3	3
Auto feed range: in./rev. (mm/rev)	.0039/.0079/.0118 (0.1-0.2-0.3)	.0039/.0079/.0118 (0.1-0.2-0.3)
Dimensions and Weights		
Height (A)	86.4" (2195mm)	90" (2285mm)
Base: Length x Width (B)	29.1" x 16.2" (740 x 412mm)	31.5" x 18.8" (800 x 476mm)
Base to spindle (C)	48.4" (1230mm)	48.4" (1230mm)
Spindle center to column (D)	11.81" (300mm)	13.78" (350mm)
Spindle to Table (E)		
Minimum	1.97" (50mm)	1.97" (50mm)
Maximum	28.5" (725mm)	27.2" (690mm)
Worktable: Length x Width (F)	15.75" x 18.9" (400 x 480mm)	18.9" x 22.05" (480 x 560mm)
Base height (G)	4.72" (120mm)	4.72" (120mm)
Column diameter (H)	4.92" (125mm)	5.91" (150mm)
Net weight	882 lbs (400Kg)	1,081 lbs (490Kg)
Shipping weight	450 lbs (992Kg)	1,190 lbs (540Kg)
Shipping dimension (L x W x H)	92" x 24" x 42" (2.34x.61x1.06m)	92" x 24" x 42" (2.34x.61x1.06m)

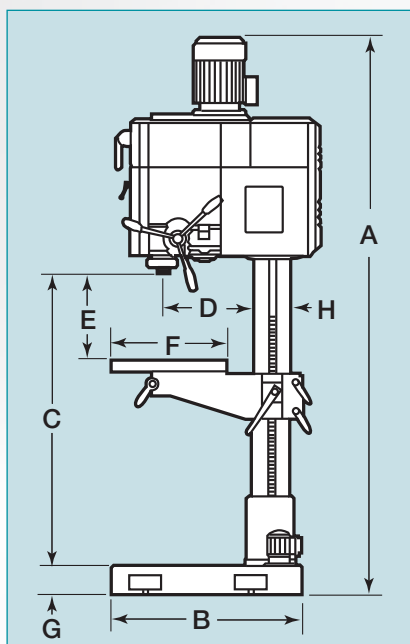

Standard motor: 1800 rpm

Spindle speeds Models SX/AXBX-34 & SX/AXBX-40
158-233-332-383-559-799-1060-1555-2222 rpm

Standard Fixed Table Models

Model	Description (Dimension see page 21)
1SX-34	23.6" (600mm) drill with Fixed Table
1AX-34	23.6" (600mm) drill with Fixed Table
1BX-34	23.6" (600mm) drill with Fixed Table
1SX-40	27.5" (700mm) drill with Fixed Table
1AX-40	27.5" (700mm) drill with Fixed Table
1BX-40	27.5" (700mm) drill with Fixed Table



The A/BX34/40 are equipped with a 3 feed rate, Mechanical Clutch Automatic Feed Control, the feed rate is easily selected by the Feed Selector

"RS" models are equipped with automatic feed reversing system for tapping.

All X34/40, Speed Selector Levers are mounted on the front of the headstock for operator convenience and fast and easy speed selection

