



# Series Z Belt-drive Round-column Drills

## *With Manual or Mechanical Clutch*

Select the Z series step pulley or variable speed belt-drive Industrial Drilling Machine that is right for the job. The SZ-32 model is equipped with manual feed and step pulley drive, the AZ-32V model is equipped with a mechanical clutch and mechanical variable speed drive.

### Standard Features and Equipment:

- Drilling capacity in steel: up to 1.26" (32mm) maximum
- Drilling capacity in cast iron: up to 1.38" (35mm) maximum
- Tapping capacity in steel: up to .87" (30mm) maximum
- Tapping capacity in cast iron: up to 1.18" (30mm) maximum
- Automatic feed reversing system for tapping on "RS" models
- Machine base with 2 T-slots, coolant tank and pump
- Large worktable with 3 T-slots,
- Feed crank wheel for manual feed
- Depth scale and adjustable depth stop
- Automatic tool ejector
- Spindle reversing switch
- Work Light
- Built-in low voltage electrical equipment in machine head
- Emergency STOP
- Drill guard with microswitch

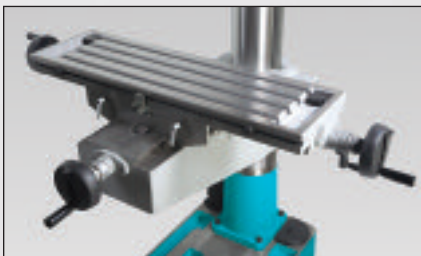

*Optional **MCC-ZX**  
15" x 8.7" cross  
slide table for  
model Z32*



*Optional **MG** rotating  
table with 3 T-slots  
for model Z32*



**SZ-32**

# Capacities, Specifications and Dimensions

Standard Models Auto feed reversing "RS" Models	SZ32	AZ32V AZ32VRS
<b>Capacities:</b>		
Maximum drilling capacity in steel	1.26" (32mm)	1.26" (32mm)
Maximum drilling capacity in cast iron	1.38" (35mm)	1.38" (35mm)
Maximum tapping capacity in steel	.87" (22mm)	.87" (22mm)
Maximum tapping capacity in cast iron	1.18" (30mm)	1.18" (30mm)
<b>Specifications:</b>		
Spindle taper	3MT	3MT
Quill diameter	2.56" (65mm)	2.56" (65mm)
Spindle travel (drilling depth)	5.91" (150mm)	5.91" (150mm)
Main motor power	1.2/1.8 Hp (.9/1.3Kw)	1.2/1.8 Hp (.9/1.3Kw)
Coolant pump motor power	.1 Hp (.07Kw)	.1 Hp (.07Kw)
Number of speeds	10	Infinitely Variable
Number of automatic feeds	-	2
Auto feed range: in./rev. (mm/rev)	-	.0039/.0079 (0.1-0.2)
<b>Dimensions and Weights</b>		
Height (A)	76.8" (1950mm)	76.8" (1950mm)
Base: Length x Width (B)	26.8" x 16.5" (680 x 420mm)	26.8" x 16.5" (680 x 420mm)
Base to spindle (C)	50.59" (1285mm)	50.59" (1285mm)
Spindle center to column (D)	11.81" (300mm)	11.81" (300mm)
Spindle to Table (E)		
Minimum	6.7" (170mm)	6.7" (170mm)
Maximum	32.87" (835mm)	32.87" (835mm)
Worktable: Length x Width (F)	15.75" x 18.9" (400 x 480mm)	15.75" x 18.9" (400 x 480mm)
Base height (G)	4.72" (120mm)	4.72" (120mm)
Column diameter (H)	4.92" (125mm)	4.92" (125mm)
Net weight	573 lbs (260Kg)	639 lbs (290Kg)
Shipping weight	683 lbs (310Kg)	750 lbs (340Kg)
Shipping dimension (L x W x H)	24" x 44" x 91" (.6x1.1x2.3m)	24" x 44" x 91" (.6x1.1x2.3m)

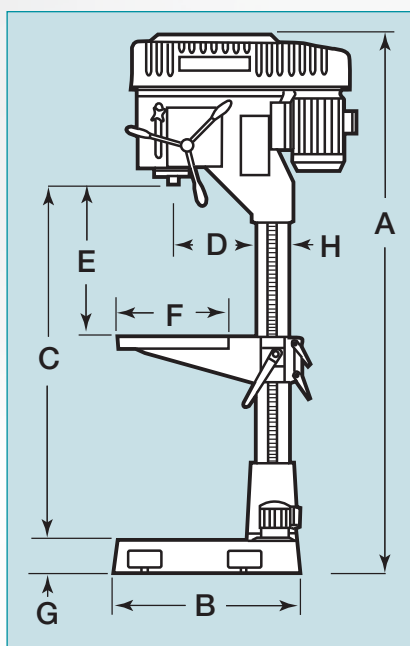

### Standard motor: 2 Speed 900/1800 rpm

Model	Spindle speeds (rpm)
SZ32	900rpm: 170-265-415-650-1035 1800rpm: 340-530-830-1300-2070
AZ32V	Infinitely Variable: 96-1405 rpm

"RS" models are equipped with automatic feed reversing system for tapping.

### Standard Fixed Table Models

Model	Description (Dimension see page 21)
1SZ32	23.6" (600mm) drill with Fixed Table
1AZ32V	23.6" (600mm) drill with Fixed Table
1AZ32VRS	23.6" (600mm) drill with Fixed Table and Tapping System



**SZ-32** model is equipped with manual feed and step pulley drive



**AZ-32V** model is equipped with a mechanical clutch and mechanical variable speed drive